

# **FAFCO**

## **SOLAR POOL HEATING SYSTEM**

---

### **OWNER'S MANUAL**

Made in the U.S.A.

Since 1969, FAFCO has been designing, testing, and producing the world's highest performing solar pool heating systems. Please read the following pages carefully to get the most out of your new solar pool heating system.

# Contents

---

- How it works..... i
- What can you expect from your solar heating system .....2
- Required winterization .....2
- Isolating solar collectors during pool maintenance.....3
- Helpful hints.....3
- Before you call for service .....4
- My solar system.....5

# How it works

---

Your pool pump circulates pool water through the solar collectors. The sun heats the water, and the heated water is returned to your pool. (See Figure 1.)

## 1. Solar collectors

Solar collectors absorb the sun's heat and transfer it to pool water.

- A. Vacuum Relief Valve**—Allows collectors to drain when the system is off.
- B. End Cap**—Removed for winterization.

## 2. Diverter Valve

### Automatic

- A. Motorized Diverter Valve**—Automatically diverts the pool water to the solar collectors.
- B. Controller**—Turns the solar system on and off based on the pool water temperature and solar collector temperature.
- C. Sun Sensor**—Senses solar collector temperature.
- D. Pool Water Sensor**—Senses the pool water temperature.

### Manual

- A. Manual Diverter Valve**—Manually diverts pool water to the solar collectors.

## 3. Isolation Valves

These valves isolate the solar collectors and **MUST BE CLOSED** during winter, filter cleaning, backwashing and vacuuming. (Refer to “Required winterization,” page 2, and “Isolating solar collector during pool maintenance,” page 3.)

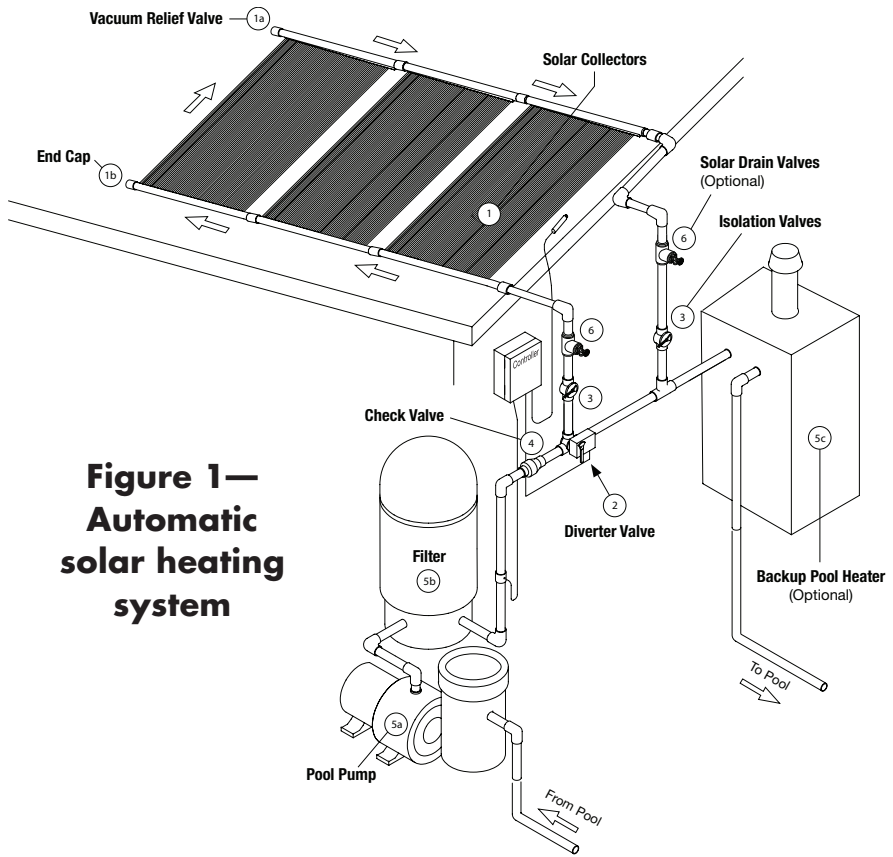

**Figure 1—  
Automatic  
solar heating  
system**

**4. Check Valve**

The check valve prevents water from flowing backward through the filter and backflushing debris into the pool when the collectors drain.

**5. Existing equipment**

- A. Pool Pump**—Circulates the pool water through the solar collectors. Some systems are installed with a booster pump.
- B. Pool Filter**—Cleans the pool water.
- C. Backup Pool Heater (optional)**—A backup heater may be installed on pools used year-round, or where a specific pool temperature is maintained regardless of weather conditions.

**6. Solar Drain Valves (optional)**

Solar drain valves allow for convenient draining during winterization.

# What can you expect from your solar heating system?\*

---

1. Significant pool temperature increase over a period of several days.
2. Extended swimming season.
3. Years of trouble-free service.
4. Increased value of your home.
5. Reduction of your carbon footprint.

\*The performance of your solar pool heating system will vary based on your geographic location, climate, and weather conditions. A pool blanket is recommended to maximize performance and reduce heat loss due to evaporation.

## Required winterization\*

---

**NOTE: COLLECTORS ARE WARRANTED AGAINST FREEZE DAMAGE WHEN INSTALLED IN STRICT ACCORDANCE WITH FAFCO'S INSTALLATION INSTRUCTIONS.**

The solar collectors must be completely drained and isolated before winter to prevent freeze damage. Solar collectors will not be damaged by freezing conditions when properly drained and isolated as follows:

1. Turn off the solar heating system.
2. Turn off the pool pump and pool sweep.
3. Open optional solar drain valves.
4. Remove end caps and vacuum relief valve. Leave off and store in a safe place for winter.
5. Let the system completely drain for at least one hour.
6. If the solar collectors are mounted at less than a 10° pitch, then the solar collectors must be manually lifted and drained. Blowing the lines with a shop vacuum, leaf blower, or compressor will **NOT** remove water completely.
7. Close isolation valve(s) for winter. (See Figure 2, on page 3.)
8. Ensure that the solar heating system remains off for winter.
9. The pool pump, filter, and sweep can now be used while remaining isolated from the solar system.

\*Operating your solar system during freezing conditions is not an approved freeze-protection method.

***Ask your dealer about winterization and spring start-up service plans.***

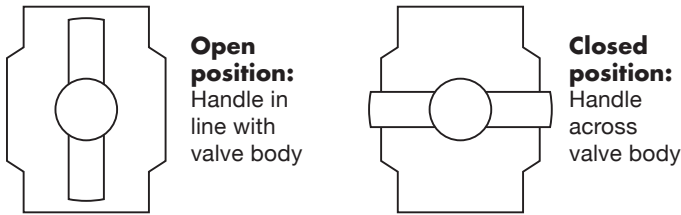

**Figure 2—Solar Isolation Valve(s)**

## Isolating solar collector during pool maintenance

---

The controller should be turned off and the solar collector isolation valves closed whenever pool maintenance is done. Follow these steps before filter cleaning, backwashing, or pool vacuuming:

1. Turn the pump off.
2. Turn the solar heating system off.
3. Close the solar isolation valves. (See Figure 2.)
4. Proceed with normal filter cleaning or vacuuming.
5. After pool maintenance is complete, run the pump for a few minutes to clear any debris from pool lines.
6. Open the solar isolation valves.
7. Turn the solar system on.

## Helpful hints

---

1. The best hours to operate your manual solar pool heating system are typically 10 AM to 6 PM. Experiment with different time settings.
2. Using a pool blanket during the spring and fall will keep nighttime heat loss to a minimum.
3. Keeping your filter and pump leaf traps clean will maximize solar performance.

# **Before you call for service\***

---

## **Automatic solar heating system does not turn on:**

1. Check to see if the pool pump is on and operating.
2. Make sure the controller is set at the “solar on” position.
3. Make sure sunshine is available at the sun sensor.
4. Check to see if the desired pool temperature has not already been reached.

\*Systems with controllers will not turn on unless the temperature is higher at the solar collectors than in the pool.

## **Solar heating system turns on, but system does not appear to be heating pool:**

1. Check that filter, pump leaf trap, and skimmer are clean.
2. Filter pump timer should be set to run during hours of maximum sunshine, typically 10 AM to 6 PM.
3. Be sure solar isolation valves are open. (See Figure 2, page 3.)
4. If nighttime temperatures have been low, using a pool blanket will help retain heat gathered by the solar heating system during the day.
5. Consider adding a pool blanket, which will increase the amount of solar heat retained in your pool by limiting evaporation and heat loss.

## **Air bubbles are present in pool water return lines throughout the day:**

A few minutes of air bubbling into the pool is normal the first time the solar heating system turns on each day. If bubbles continue past the initial “purge”, this is usually an indication that the water flowing through the filter system and to the solar collectors has been reduced. Be sure to clean filter and pump leaf traps.

## **Water leaking from roof:**

Your solar collectors may appear to leak briefly in the morning due to normal overnight condensation runoff, just like the condensation on your car’s windshield. If the drip continues throughout the day, the most common cause is a loose clamp, which can be tightened with a screwdriver.

For more information visit [FAFCO.com](http://FAFCO.com)

# **My solar system**

---

Installation company \_\_\_\_\_

Installation date \_\_\_/\_\_\_/\_\_\_

Solar collector model \_\_\_\_\_

Solar collector size(s) \_\_\_\_\_

Quantity \_\_\_\_\_

Controller model \_\_\_\_\_

Notes \_\_\_\_\_

---

---

---

---

---

---

---

---

---

---

---

---

---

---

---

---

---

---

---

---

---

---

---

---

---

---

Authorized FAFCO dealer